



# **JMY350B\_370B RFID Access Reader/Writer User Manual**

---

(Revision 1.7)

**Beijing Jilmuyu Electronics Co., Ltd**

**2026/1/9**



## Content

1	Characteristics .....	4
2	Pin configurations and Pin outs .....	4
2.1	JMY350B .....	4
2.2	JMY370B .....	6
3	Communication Protocols .....	7
3.1	RS485 Protocol .....	7
3.2	Wiegand Protocol .....	8
4	Description of commands .....	9
4.1	List of commands .....	9
4.2	Explanation of commands .....	9
5	Encryption Output Function .....	18
5.1	Data Format .....	18
5.2	Data Encryption and Decryption .....	20
6	Part of Protocols .....	21



## File modification history

Date	Version	Modification
---	V1.0	Create a new document
2019.12.22	V1.1	Added an introduction to BLE host mode.
2020.04.15	V1.2	Added a description of BLE slave mode.
2021.03.04	V1.3	Instructions for modifying card reader parameters settings
2021.03.23	V1.4	Modify pin definitions
2021.04.06	V1.5	Modify the limiting description of the command for writing script information.
2022.03.30	V1.6	Add card type settings
2026.01.09	V1.7	Added command for reading parameters. Added support for ISO15693 card type. Updated description of modifying configuration parameters. Updated description of default pin definitions.



# 1 Characteristics

- Supported standard: ISO14443-4 TYPE A+B/ISO15693
- Power supply: DC 12V
- Interface: RS485,Wigand
- Power consumption: 100mA
- Operating distance: 0-8cm (depending on card and antenna design)
- ISP: Supported
- Operating temperature: -25~+85 °C
- Storage temperature: -40 ~ +125 °C

## 2 Pin configurations and Pin outs

### 2.1 JMY350B

Pin1	Pin2	Pin3	Pin4	Pin5	Pin6	Pin7	Pin8	Pin9	Pin10
Down	Up	+12V	GND	D+	D-	Bit1	Bit0	GND	IO
		Red	Black	Yellow	Green			Brown	White
Cover protection	Power		RS485		Wigand		Onekey		
Reserve			RS485 default				Customized		

PCB:

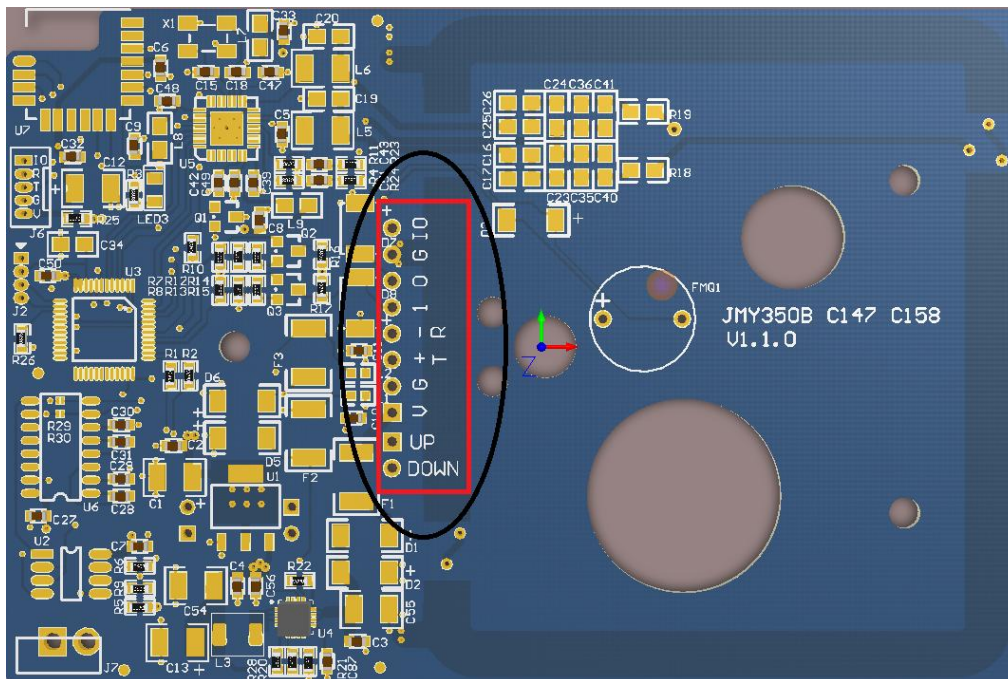



Front (with Housing)

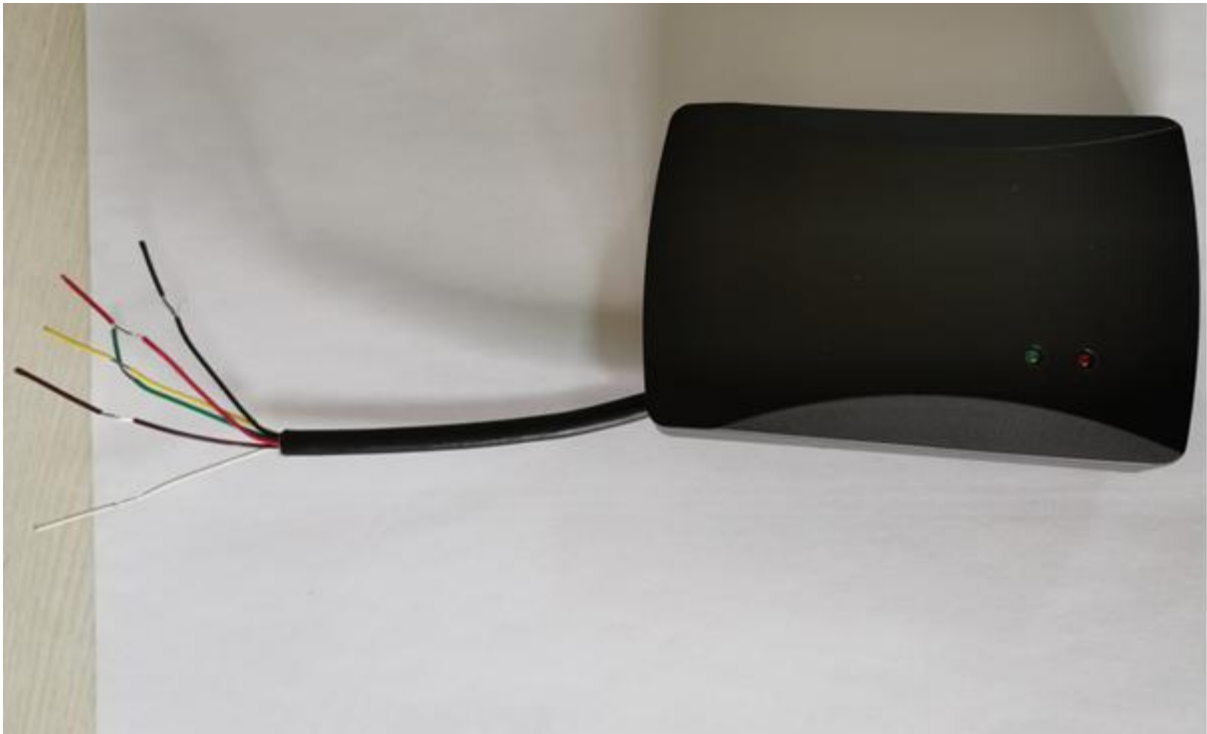

Back (with Housing)





## 2.2 JMY370B

J1:

Pin1	Pin2	Pin3	Pin4	Pin5	Pin6
IO	GND	Bit0	Bit1	GND	+12V
White	Brown			Black	Red
Onekey		Wigand		Power	
Customized		Can be chosen			

J4:

Pin1	Pin2	Pin3	Pin4
Up	Down	D+	D-
		Yellow	Green
Cover protection		RS485	
Reserve		Default	

PCB:

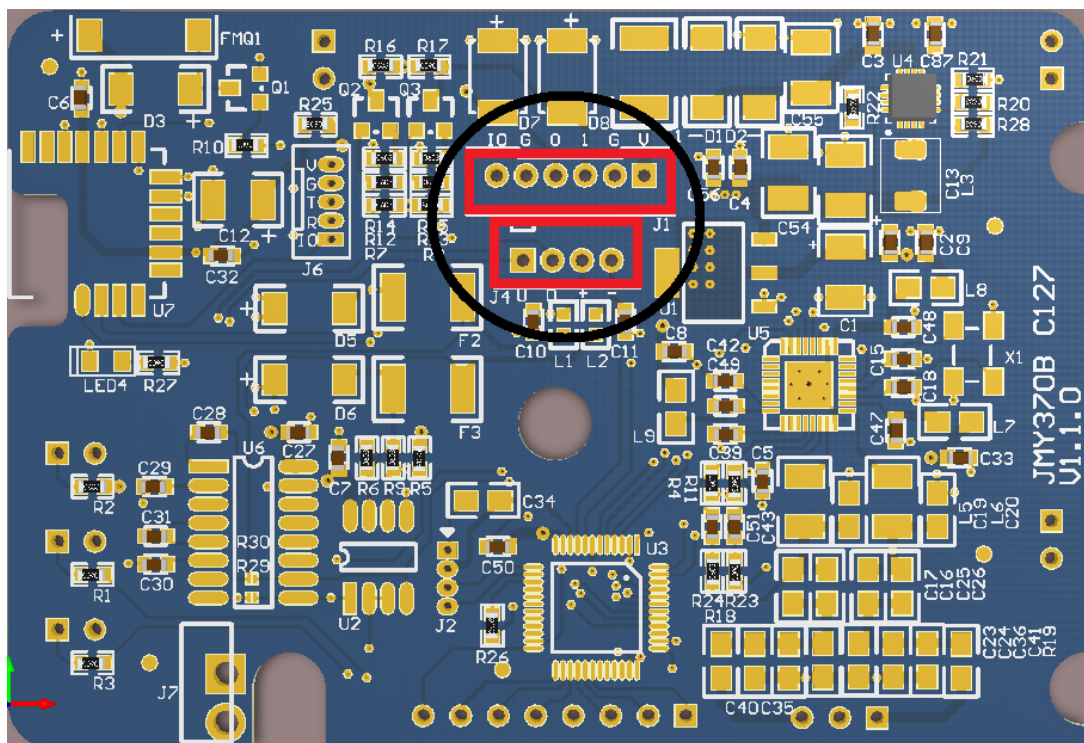



Front (with Housing)

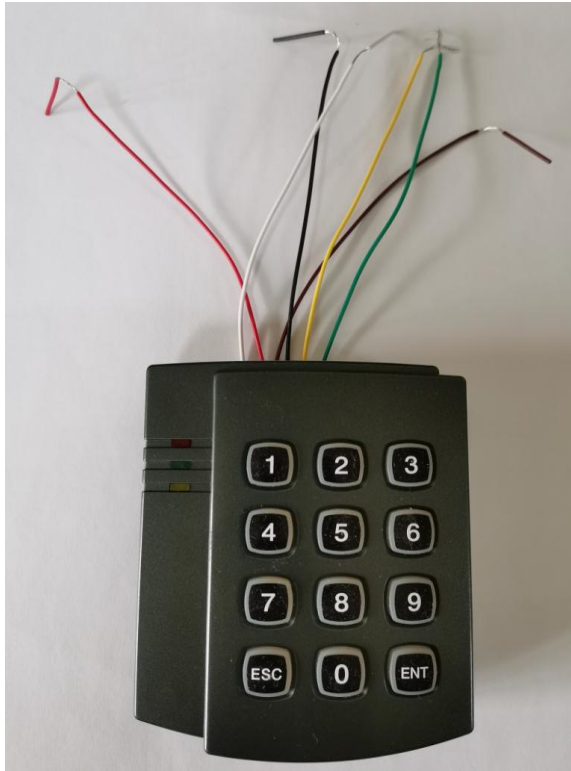

Back (with Housing)

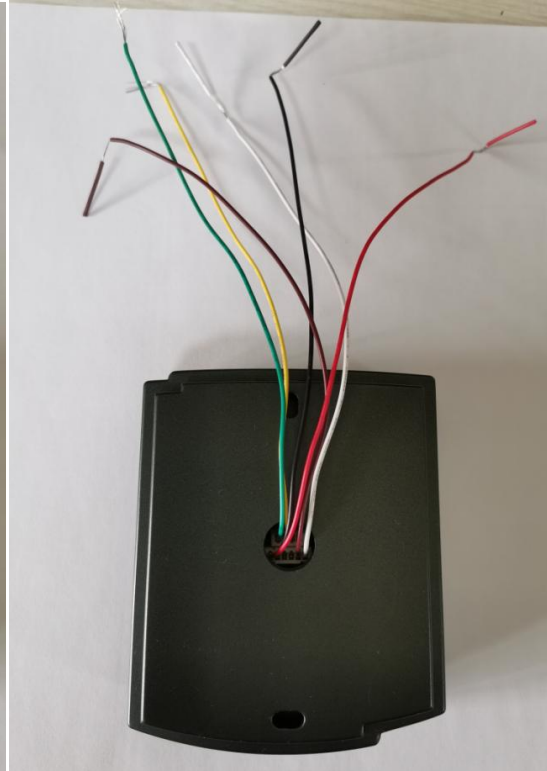

## 3 Communication Protocols

### 3.1 RS485 Protocol

#### 3.1.1 Parameters

The communication protocol is byte oriented. Both sending and receiving bytes are in hexadecimal format. The communication parameters are as follows:

- Baud rate: 19200 bps
- Data bits: 8bits
- Stop bits: 1bit
- Parity check: None
- Flow control: None

#### 3.1.2 JCP04 Data send format

Length	Command	Data	Checksum
--------	---------	------	----------

- Length: 1 byte, number of bytes from Command length byte to the last byte of Data.
- Command: 1 byte, the command of this instruction.
- Data: length depends on the command type; Data Length: 0x00~0xFC.



- Checksum: 1 byte, Exclusive OR (XOR) results from length byte to the last byte of data.

### 3.1.3 JCP04 Data return format

- Success:

Length	Command	Data	Checksum
--------	---------	------	----------

- Failure:

Length	Invert Command	Checksum
--------	----------------	----------

### 3.1.4 JCP05 Data send format

Length	C.A.	Command	Data	Checksum
--------	------	---------	------	----------

- Length: 2 bytes, number of bytes from Length byte to the last byte of Data, MSB first, length from 0x0004 to 0x01FE.
- C.A. (communication address): 1 byte, the address is multi-device communication, Default address: 0x01; broadcast address: 0x00.
- Command: 1 byte, Application-layer command.
- Data: length depends on the command type, length from 0 to 506 bytes; depending on the processor, and some models will be less than 506 bytes.
- Checksum: 1 byte, Exclusive OR (XOR) results from length byte to the last byte of data.

### 3.1.5 JCP05 Data return format

- Success:

Length	C.A.	Command	Data	Checksum
--------	------	---------	------	----------

- Failure:

Length	C.A.	Invert Command	Checksum
--------	------	----------------	----------

## 3.2 Wiegand Protocol

Supports Wiegand 26/34/42/50.



## 4 Description of commands

### 4.1 List of commands

Command code	function
0x18	Set Multi-device Communication Address
0x20	ISO14443 TYPE A Request
0x30	ISO14443-4 TYPE A Card RATS
0x31	ISO14443 Type A CPU Card Command
0x60	ISO14443-4 TYPE B Card RATS
0x61	ISO14443-4 TYPE B Card COS Command
0xA0	Write the script
0xA1	Read the script
0xA2	Clear script
0xA5	Set Reader parameter
0xA6	Read Reader parameter setting
0xA8	Read the 8-byte encrypted random
0xA9	Setting communication key
0xAF	Save reader parameters
0xB0	Set Buzzer and LED
0xB1	BLE Enable(power on enable)
0xB2	BLE Disable
0xB3	Set Scan Range
0xB4	Scan BLE Device(MAC address)
0xB5	Soft reset Bluetooth interface
0xB6	Hard reset Bluetooth interface
0xB7	Set up automatic scanning
0xB8	Bluetooth working mode setting
0xB9	Bluetooth broadcast name setting
0xF1	Version Information

### 4.2 Explanation of commands

#### 4.2.1 Set Multi-device Communication Address

Host sends:

Frame	0x18	Addr.:	Checksum
-------	------	--------	----------

Addr.: 1byte, 0x01~0xFF, can't be 0x00, default 0x01.

**Success:**

Frame	0x18	Checksum
-------	------	----------

**Failure:**

Frame	0xDF	Checksum
-------	------	----------

### 4.2.2 ISO14443 Type A Request

**Host sends:**

Frame	0x20	Mode	Checksum
-------	------	------	----------

Mode: 0x26 REQA

0x52 WUPA

**Success:**

Frame	0x20	SNR	Checksum
-------	------	-----	----------

SNR: 4, 7 or 10 bytes card serial number

**Failure:**

Frame	0xDF	Checksum
-------	------	----------

### 4.2.3 ISO14443 Type A CPU card RATS

**Host sends:**

Frame	0x30	Checksum
-------	------	----------

**Success:**

Frame	0x30	ATS	Checksum
-------	------	-----	----------

ATS: length depends on card.

**Failure:**

Frame	0xCF	Checksum
-------	------	----------

### 4.2.4 ISO14443 Type A CPU card COS Command

**Host sends:**

Frame	0x31	COS Command	Checksum
-------	------	-------------	----------

COS Command: Communication commands conforming to ISO14443-4.

**Success:**

Frame	0x31	COS Respond	Checksum
-------	------	-------------	----------

**Failure:**

Frame	0xCE	Checksum
-------	------	----------



As example(JCP05):

Send: 0x0009 00 31 00 84 00 00 08 B4

Return: 0x000E 01 31 B9 89 3A B0 16 40 7E D0 90 00 EC

#### 4.2.5 ISO14443 Type B CPU card RATS

**Host sends:**

Frame	0x60	Mode	Checksum
-------	------	------	----------

Mode: 1byte, 0x00 WUPB; 0x01: REQB; RFU

**Success:**

Frame	0x60	Info.	Checksum
-------	------	-------	----------

Info. : For more details, please refer to ISO14443-3 "ATQB Response" part.

**Failure:**

Frame	0x9F	Checksum
-------	------	----------

#### 4.2.6 ISO14443 Type B CPU card COS Command

**Host sends:**

Frame	0x61	COS Command	Checksum
-------	------	-------------	----------

**Success:**

Frame	0x61	COS Respond	Checksum
-------	------	-------------	----------

**Failure:**

Frame	0x9E	Checksum
-------	------	----------

#### 4.2.7 Write into the script information

Before writing script information, you need to send A2h command ([clear card reader parameters and script data command](#)) to get permission. Power on again, the authority will be invalid.

**Host sends:**

Frame	0xA0	DATA	Checksum
-------	------	------	----------

DATA: Script Commands

This document describes only the serial communication structure, specific script information structure, and method of use, please refer to the "Script protocol file."

**Success:**

Frame	0xA0	Checksum
-------	------	----------

**Failure:**

Frame	0x5F	Checksum
-------	------	----------

**4.2.8 Read out the script information****Host sends:**

Frame	0xA1	INDEX	Checksum
-------	------	-------	----------

INDEX: Specify the script command number.

**Success:**

Frame	0xA1	DATA	Checksum
-------	------	------	----------

DATA: Script Commands

This document describes only the serial communication structure, specific script information structure, and method of use, please refer to the "Script protocol file."

**Failure:**

Frame	0x5E	Checksum
-------	------	----------

**4.2.9 Clear reader parameters and script data****Host sends:**

Frame	0xA2	Flag	Checksum
-------	------	------	----------

Flag: 1byte, 0xFF

**Success:**

Frame	0xA2	Checksum
-------	------	----------

**Failure:**

Frame	0x5D	Checksum
-------	------	----------

**4.2.10 Reader parameter setting**

To set the reader to find cards, script execution and output functions.

**Host sends:**

Frame	0xA5	DATA	Checksum
-------	------	------	----------

DATA 4bytes:

	Bit	Explanation
DATA[0]	Bit7	RFU



	Bit6	1=Enable; 0=Disable; The output data encryption.
	Bit5	1=Enable; 0=Disable; Data output from RS485 port.
	Bit4	1=Enable; 0=Disable; Data output from Wiegand port.
	Bit3-bit0	3 = Wiegand26 or RS485 three bytes 4 = Wiegand34 or RS485 four bytes 5 = Wiegand42 or RS485 five bytes 6 = Wiegand50 or RS485 six bytes 7 = Wiegand58 or RS485 seven bytes 8 = Wiegand66 or RS485 eight bytes 9 = Wiegand74 or RS485 nine bytes 10 = Wiegand80 or RS485 ten bytes
DATA[1]	Bit7	1=Enable; 0=Disable; Automatic detecting card
	Bit6	1=Enable;0=Disable; Automatic key finding function
	Bit5	1=Enable; 0=Disable; Using a script.
	Bit4-bit3	RFU
	Bit1	1=Enable; 0=Disable; The buzzer will sound once after successful card detection.
	Bit0	1=Enable; 0=Disable; The green LED flashes once after successful card detection.
DATA[2]		Card Type 0x00: Type A (default) 0x01: ISO15693
DATA[3]		Device Address

Note: When using RS485 output, the first byte of data is fixed as the device address.  
For example: Reader parameter setting: 34 80 00 02; Card UID: "00112233".  
The default RS485 output will be 5 bytes: "0200112233".

**Success:**

Frame	0xA5	Checksum
-------	------	----------

**Failure:**

Frame	0x5A	Checksum
-------	------	----------

**4.2.11 Reading card reader parameters**

Read the configuration parameters of the card reader.

**Host sends:**

Frame	0xA6	Checksum
-------	------	----------

**Success:**

Frame	0xA6	DATA	Checksum
-------	------	------	----------

DATA: 4 bytes, refer to the description of the command for setting card reader parameters.

**Failure:**

Frame	0x59	Checksum
-------	------	----------

**4.2.12 Save reader parameters****Host sends:**

Frame	0xAF	Checksum
-------	------	----------

**Success:**

Frame	0xAF	Checksum
-------	------	----------

**Failure:**

Frame	0x50	Checksum
-------	------	----------

**4.2.13 Read the 8-byte encrypted random**

Read the 8-byte encrypted random number. The default card reader key is 4A494E4D55595520. This key is a fixed value; please keep it safe.

**Host sends:**

Frame	0xA8	Checksum
-------	------	----------

**Success:**

Frame	0xA8	E.R.	Checksum
-------	------	------	----------

E.R (Encrypted random number): 8 bytes. Used as the DES encryption key for the "encrypted data function" output by the reader/writer device.

**Failure:**

Frame	0x57	Checksum
-------	------	----------

**4.2.14 Setting communication key****Host sends:**

Frame	0xA9	E.D.	Checksum
-------	------	------	----------

E.D. (Encrypted Data): 16byte (the Host encrypts the key via DES, then send to the Reader.)

**Success:**

Frame	0xA9	Checksum
-------	------	----------

**Failure:**

Frame	0x56	Checksum
-------	------	----------



#### 4.2.15 Set Buzzer and LED

**Host sends:**

Frame	0xB0	DATA	Checksum
-------	------	------	----------

DATA[0]: LED and Buzzer Control

Bit5 Green LED reverses display

Bit4 Red LED reverses display

Bit3 RFU

Bit2 Beep Control

Bit1 Green LED Control

Bit0 Red LED Control

DATA[1-2]: MSB first, beep control time (unit: 10ms).

DATA[3-4]: MSB first, Green LED control time (unit: 10ms).

DATA[5-6]: MSB first, Red LED control time (unit: 10ms).

**Success:**

Frame	0xB0	Checksum
-------	------	----------

**Failure:**

Frame	0x4F	Checksum
-------	------	----------

As Following:

Red LED reverse display; Green LED display, Buzzer beep:

Host sends: 09 B0 17 00 0A 00 0A 00 0A A4

#### 4.2.16 BLE Enable

Note: After the BLE module is reset or disabled, you need to re-enable the BLE function before you sending config commands to the Bluetooth device. The reader is enabled by default at power-up.

**Host sends:**

Frame	0xB1	Checksum
-------	------	----------

**Success:**

Frame	0xB1	Checksum
-------	------	----------

**Failure:**

Frame	0x4E	Checksum
-------	------	----------



#### 4.2.17 BLE Disable

Note: This command can be sent only after the BLE function is enabled.

**Host sends:**

Frame	0xB2	Checksum
-------	------	----------

**Success:**

Frame	0xB2	Checksum
-------	------	----------

**Failure:**

Frame	0x4D	Checksum
-------	------	----------

#### 4.2.18 Soft reset Bluetooth interface

Note: This command can be sent only after the BLE function is enabled.

**Host sends:**

Frame	0xB5	Checksum
-------	------	----------

**Success:**

Frame	0xB5	Checksum
-------	------	----------

**Failure:**

Frame	0x4A	Checksum
-------	------	----------

#### 4.2.19 Hard reset Bluetooth interface

**Host sends:**

Frame	0xB6	Checksum
-------	------	----------

**Success:**

Frame	0xB6	Checksum
-------	------	----------

**Failure:**

Frame	0x49	Checksum
-------	------	----------

#### 4.2.20 Bluetooth working mode setting

**Host sends:**

Frame	0xB8	Mode	Checksum
-------	------	------	----------

Mode: 0x4D – Master (Default)

0x53 - Slave

**Success:**

Frame	0xB8	Checksum
-------	------	----------

**Failure:**

Frame	0x47	Checksum
-------	------	----------

**4.2.21 Set scan range in host mode****Host sends:**

Frame	0xB3	Signal	Checksum
-------	------	--------	----------

Signal: Scan field, from 0~0x40, Max.: Default.

**Success:**

Frame	0xB3	Checksum
-------	------	----------

**Failure:**

Frame	0x4C	Checksum
-------	------	----------

**4.2.22 Scan BLE Device in host mode**

Note: You need to enable the BLE command function before you can send the change command. Only the host mode is valid.

**Host sends:**

Frame	0xB4	Checksum
-------	------	----------

**Success:**

Frame	0xB4	Checksum
-------	------	----------

**Failure:**

Frame	0x4B	Checksum
-------	------	----------

**4.2.23 Set auto scan enable in host mode**

Note: Only the host mode is valid.

**Host sends:**

Frame	0xB7	Enable	Checksum
-------	------	--------	----------

Enable: 1byte

	Bit	Description
Enable	Bit7	1=Enable; 0=Disable; auto scan enable;
	Bit6~bit4	Must be 0 in default
	Bit3~bit0	Auto scan interval, in seconds, (minimum 1 second, default 10 seconds)

**Success:**

Frame	0xB7	Checksum
-------	------	----------

**Failure:**

Frame	0x48	Checksum
-------	------	----------

**4.2.24 Bluetooth broadcast name setting**

Note: You need to enable the BLE command function before you can send the change command.

**Host sends:**

Frame	0xB9	Name	Checksum
-------	------	------	----------

Name: Hexadecimal, length (1~15 bytes).

**Success:**

Frame	0xB9	Checksum
-------	------	----------

**Failure:**

Frame	0x46	Checksum
-------	------	----------

**4.2.25 Version Information****Host sends:**

Frame	0xF1	Checksum
-------	------	----------

**Success:**

Frame	0xF1	V.I.	Checksum
-------	------	------	----------

V.I. (Version Information): Including the software version number and date information.

Both are returned as ASCII.

**Failure:**

Frame	0x0E	Checksum
-------	------	----------

## 5 Encryption Output Function

This function actively outputs fixed 8-byte DES encrypted data. The server can decrypt the 8-byte data using DES to recover the original data; the password data is the encrypted 16-byte data.

### 5.1 Data Format



### 5.1.1 Card UID

4/7/8/10Byte	2Byte	1Byte	1Byte
Card UID	Random	Instruction code	Checksum

Card UID: The card UID read by the card reader.

Random: DES encryption yields 8-byte different results.

Instruction code: 0x01

Checksum: The first 7 bytes are used for XOR checksum verification.

As Following:

Card UID: 12345678; Random: 0000; Instruction code: 01; Checksum: 09.

Data (8bytes): 1234567800000109

### 5.1.2 Button (Ring)

4Byte	2Byte	1Byte	1Byte
Data Code	Random	Instruction code	Checksum

Data code: Fixed at 01000000.

Random: DES encryption yields 8-byte different results.

Instruction code: 0x81

Checksum: The first 7 bytes are used for XOR checksum verification.

As Following:

Doorbell pressed: 01000000; Random number: ADC3; Indicator code: 81; Checksum: EE;

8-byte sequence: 01000000ADC381EE

Note: The output result will be automatically encrypted (DES ECB mode). Default key: 1122334455667788

### 5.1.3 KEY

8Byte	6Byte	1Byte	1Byte
Data Code	Random	Instruction code	Checksum

Data code: 8bytes KEY.

Random: 6bytes

Instruction code: 0x08

Checksum: The first 15 bytes are used for XOR checksum verification.

Description:

The password space reserves 8 bytes, the password length is 4 ~ 8 bytes, the length complements 8 bytes, and the end is supplemented with 0.



As Following:

Key: 1122334455667788

Ciphertext: 178F59F8578E0D3F FA2AEF9C7CA5716E

Plaintext: 0102030405060708 1B2625202F2A 08 3D

Ciphertext: 0806C51B5B060577 B003436BED45CEA6

Plaintext: 0009080700000000 3A3530330E0A 08 06

### 5.1.4 BleMAC

6Byte	1Byte	1Byte
Data Code	Instruction code	Checksum

Data Code: 6bytes BleMAC address

Instruction code: 0x10

Checksum: The first 7 bytes are used for XOR checksum verification.

## 5.2 Data Encryption and Decryption

Taking the output of card UID data from a card reader as an example:

Assumed key: 123456789ABCDEF0

Data: 1234567800000109

Encrypted result: E87510B61BF92C02

密钥: **Key**

数据: **Data**

结果: **Result**

**Encrypted**
**Decrypted**

提示: 如果密钥为8字节, 为DES算法, 如果  
密钥为16字节, 则为3DES算法. 另外, 牛

### Data Decryption in the server side:

Data (received by server): E87510B61BF92C02

Decryption result: 1234567800000109



密钥:	123456789ABCDEF0
数据:	E87510B61BF92C02
结果:	1234567800000109

提示: 如果密钥为8字节, 为DES算法, 如果  
密钥为16字节, 则为3DES算法. 另外, 生

## 6 Part of Protocols

Setting Key Process:

**The first step: to read encrypted random.**

Host sends: 02 A8 AA

Reader returns success: 0A A8 15FD10A8EA65723D 32

15FD10A8EA65723D the 8-byte encrypted random; Decrypted data reduction for AAAAAAAAAAAAAAAAAA。



**The second step: to configure data encryption key.**

If the data encryption key is 123456789ABCDEF0

Then the raw data to be sent is AAAAAAAAA 12345678 AAAAAAAAA 9ABCDEF0.

**The third step: to encrypt data.**

To do twice encryption process for the 16 bytes of raw data via using Reader's default key.



SmartCOS 工具

DES | MAC | RSA | HASH | LRC

密钥: 1122334455667788

数据: AAAAAAAAA12345678

结果: efaa9df287711279

提示: 如果密钥为8字节, 为DES算法, 如果  
密钥为16字节, 则为3DES算法. 另外, 生  
成子密钥和过程密钥只适用于SAM卡.

加密 解密  
生成子密钥 生成过程密钥

SmartCOS 工具

DES | MAC | RSA | HASH | LRC

密钥: 1122334455667788

数据: AAAAAAAAA9ABCDEF0

结果: fae5201cb8639038

提示: 如果密钥为8字节, 为DES算法, 如果  
密钥为16字节, 则为3DES算法. 另外, 生  
成子密钥和过程密钥只适用于SAM卡.

加密 解密  
生成子密钥 生成过程密钥

Then get the last encrypted data is efaa9df287711279fae5201cb8639038

**The fourth step: to set data encryption key.**

Host sends: 12 A9efaa9df287711279fae5201cb8639038 5C

Reader returns success: 02 A9 AB

Note: If the Reader returns result data successfully, it means the encryption data key be set successfully.